

VAL-MATIC®

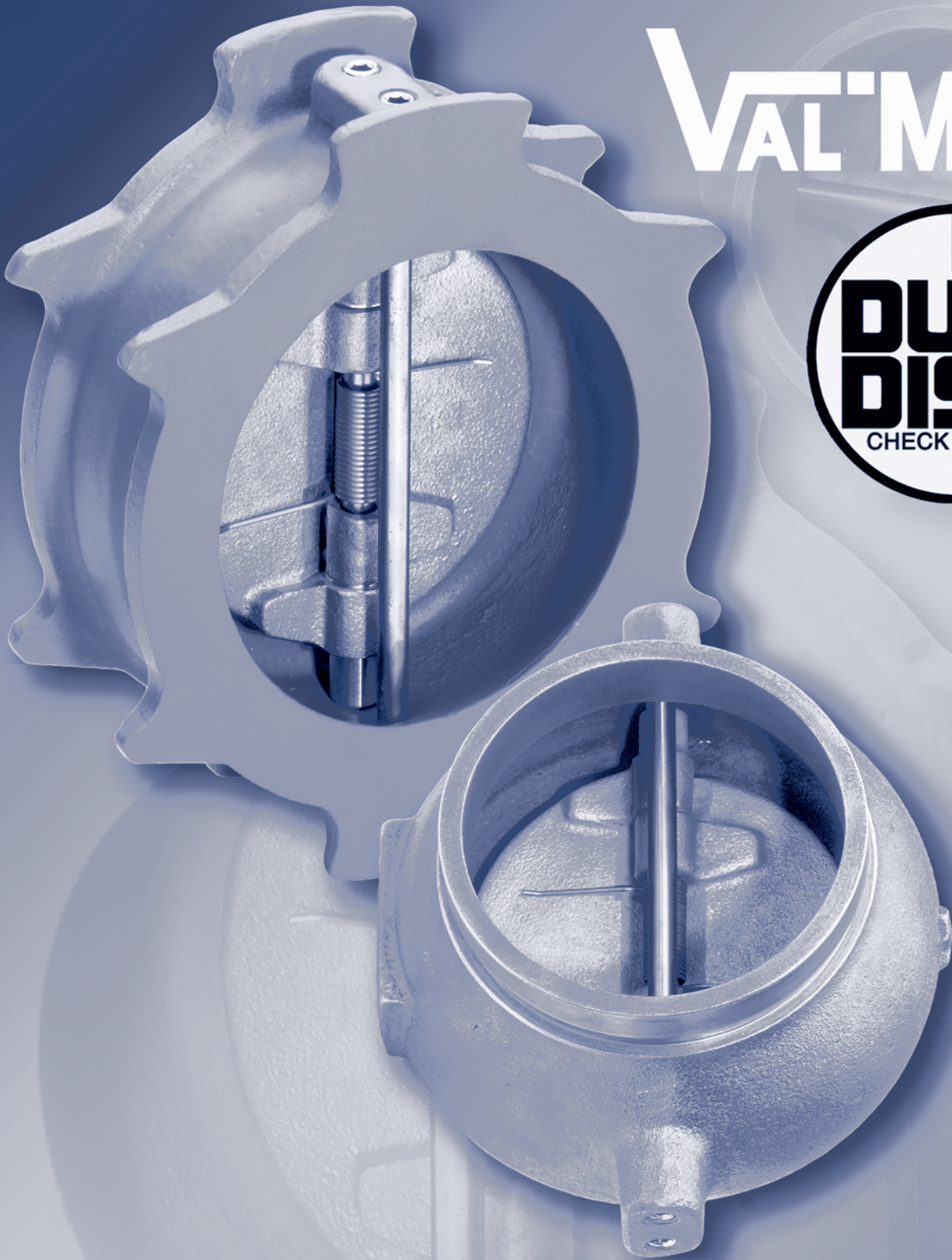

**Cost Efficient and
Reliable....
Right From the Start**

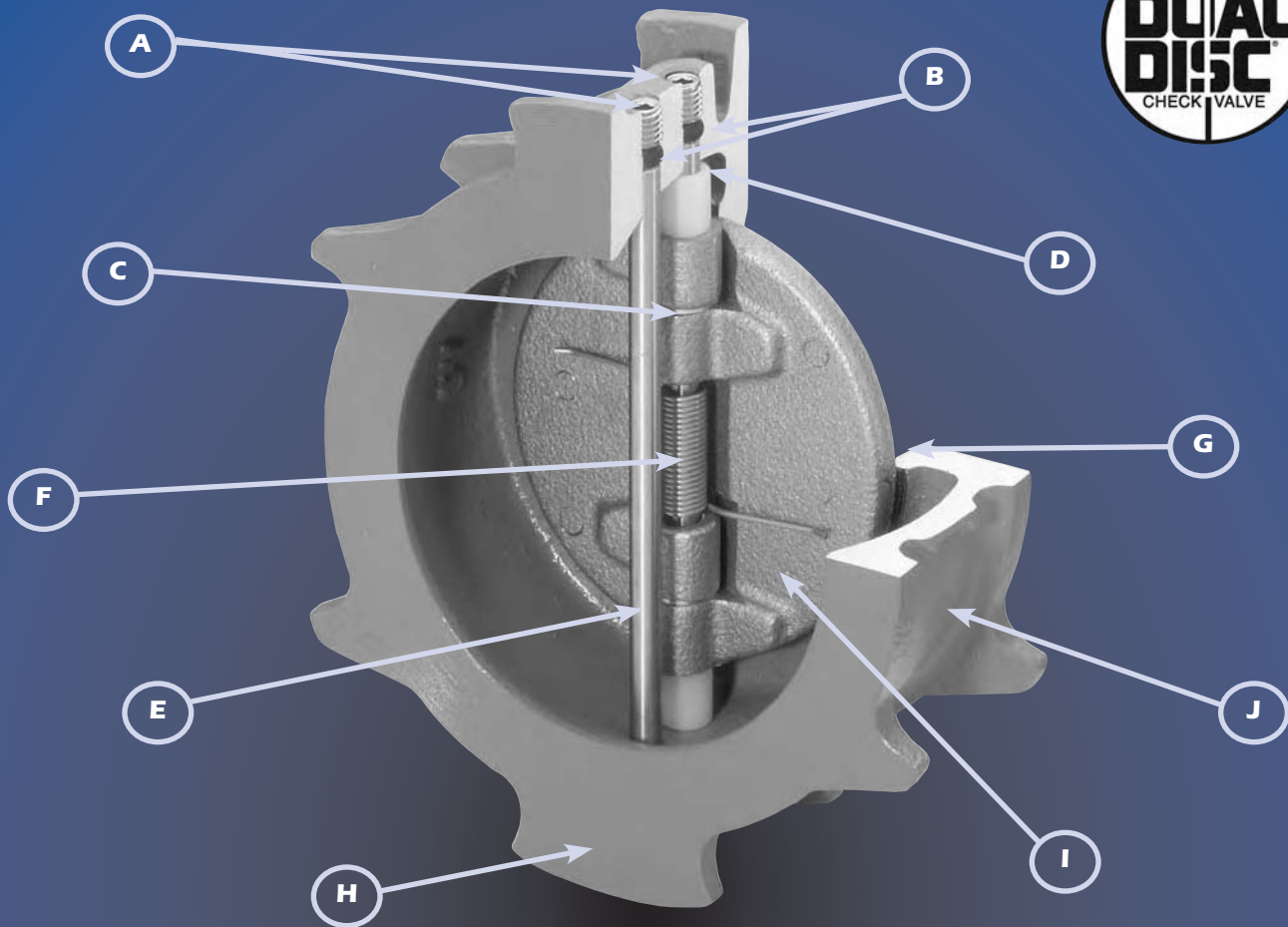

A. RETAINER PLUGS

Retain hinge and stop pins while providing compression to stabilization spheres.

B. STABILIZATION SPHERES

Stabilize hinge and stop pins, preventing vibration and wear.

C. THRUST BEARINGS

Reduce friction and wear during disc action.

D. HINGE PIN

Heavy duty construction with increased bearing surface and strength.

E. STOP PIN

Positions discs on slight angle during flow preventing disc flutter.

F. SPRING

Specially designed torsion spring closes discs upon pump shutdown minimizing water hammer normally associated with valve shutoff. Also provides for Lift and Pivot disc action. Cycle tested 50,000 cycles to assure long, trouble free life.

G. VULCANIZED SEAT

Pressure sensitive seating with full disc overlap provides positive seating at high and low pressures.

H. ALIGNMENT FINES

Provide for precise alignment in ANSI 125 and ISO PN10 and PN16 installations. (Patent Pending.)

I. DISC

Dual Disc design increases valve sensitivity to flow, allowing discs to close quickly on pump shutdown.

J. BODY

Choose between compact wafer design to minimize space requirements (pictured) or grooved end for ease of installation. Both provide low initial installation cost and minimal maintenance. Compact wafer style reduces installation time, minimizes space required for installation, and results in low initial unit cost. Alignment fins provide precise alignment for ANSI 125 and ISO PN10 and PN 16 installations.



DESIGN FEATURES

...THAT MAKE VAL-MATIC DUAL DISC® CHECK VALVE COST EFFICIENT & RELIABLE

With today's demanding system requirements, engineers must specify piping components that are both COST EFFICIENT and RELIABLE. The design of the Val-Matic DUAL DISC® Check Valve answers those needs by incorporating many unique characteristics not found in similar check valves. 2" - 12" (50 -300mm) valves include Ductile Iron construction, with a 250 psi (17.2 BAR), cold working pressure rating. They are UL/FM approved and available in Wafer (ANSI 125, ISO PN10, ISO PN16) and Grooved End IPS connections. Sizes 14" (350mm) and larger are available in cast and ductile iron.

INSTALLATION COST: Choose between compact wafer design to minimize space requirements or grooved end for ease of installation. Both provide low initial installation cost and minimal maintenance. The following quality features you expect from Val-Matic can be found in both the wafer and grooved end valves.

OPERATING COST: Careful attention to inlet contouring and streamlined flow design, combined with an expansive flow area, result in unusually low pressure loss characteristics. The resulting low power consumption translates into dollar savings throughout the long life of the valve.

PRODUCT RELIABILITY: Design features such as Lift and Pivot Disc Action, Disc Seal Overlap, Pressure Sensitive Seating, Stabilization Spheres, Disc Stabilization, and Flow Sensitive Closure, combined with careful selection of materials of construction, reflect Val-Matic's efforts to build a quality valve. These efforts result in a COST EFFICIENT and RELIABLE product that will provide many years of trouble free service.

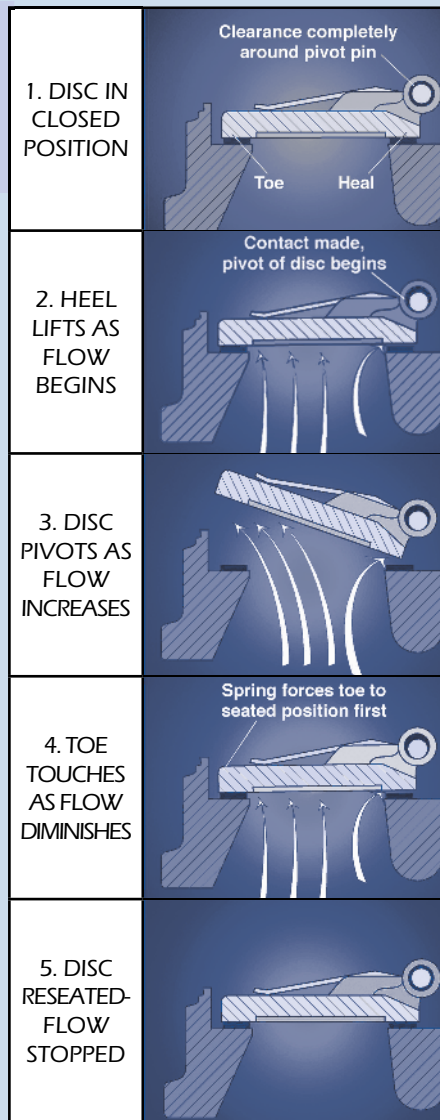

LIFT AND PIVOT DISC ACTION: This feature, designed to give longer valve life, is activated during the opening and closing cycles. It works by a combination of clearance between the pivot pin and disc bores, and the placement of the legs of the torsion spring. With this design the disc will always lift first at the pivot on opening, and not return until the disc is closed, preventing wear between disc and seat surfaces.

STABILIZATION SPHERES: These resilient, synthetic spheres inserted into the pivot and stop pin holes are compressed against the pins and effectively stabilize them during flow conditions, eliminating vibration and wear.

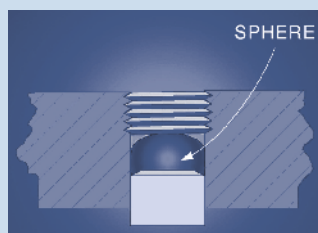

PRESSURE SENSITIVE SEATING: This design provides for minimum disc-to-seat contact at low pressures, and maximum contact at high pressures resulting in positive seating at all times without seal destruction.

DISC STABILIZATION: When the valve is fully open, the discs are positioned on a slight angle, causing the flow velocity to force the discs firmly against the stop pin. The ensuing vector forces act to stabilize the disc during flow conditions thereby preventing excessive wear due to disc "flutter."

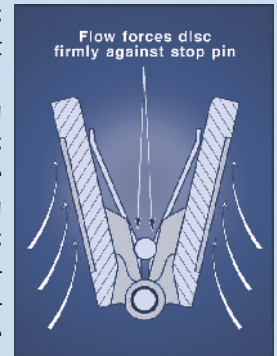

DISC SEAL OVERLAP: Contact between the seal and the disc is uniquely designed to eliminate indentation ridges found in designs which do not allow the disc to fully overlap the seal. Indentation ridges caused by valve designs with discs smaller in diameter than the seal can result in valve leakage.



FLOW SENSITIVE CLOSURE: The torsion spring closes the valve when the flow is reduced, preventing flow reversal and lessening the potential for water hammer normally associated with conventional swing check valves.

Maximum Pressure-Temperature Ratings

Maximum Non-Shock Working Pressure **PSIG (BAR)** ANSI Class 125, ISO PN 10 - 16

Temp.	Cast Iron			Temp.	Cast Iron		
	Ductile Iron	Cast Iron	Cast Iron		Ductile Iron	Cast Iron	Cast Iron
F	2" - 12"	14" - 24"	30" - 60"	C	50 - 300mm	350 - 600mm	750 - 1500mm
150	250	150	150	65	17.2	10.3	10.3
200	235	135	115	95	16.2	9.3	7.9
250	220	125	85	120	15.2	8.6	5.9
Hydro Test	500	230	230	Hydro Test	35	16	16

Materials of Construction

Component		Standard		Optional
Body	2" - 12"	50 - 300mm	Ductile Iron ASTM A536 Gr. 65-45-12	N/A
	14" - 60"	350 - 1,500mm	Cast Iron ASTM A126, Class B	Ductile Iron ASTM A536 Gr. 65-45-12
Disc	2" - 12"	50 - 300mm	Bronze ASTM B584, C83600	N/A
	14" - 60"	350 - 1,500mm	Aluminum Bronze ASTM B148, Alloy C95200	Ductile Iron, Electroless Nickel Plated
Seal		Buna-N (NBR)		Viton (FKM)
Spring		316 SS (2"-16"/50-400mm), 17-7 PH (18"-60"/450-1,500mm)		N/A
Trim		316 Stainless Steel		N/A
Exterior Coating		Universal Primer		ANSI/NSF 61 Fusion Bonded Epoxy*

*FBE also available on interior.

FLOW COEFFICIENTS

Series	Size									
	IN	2"	2.5"	3"	4"	5"	6"	8"	10"	12"
	8800W	*Cv	76	161	224	400	648	1,060	1,890	3,340
Series	Size									
	IN	2"	2.5"	3"	4"	5"	6"	8"	10"	12"
	8800G	*Cv	77	129	209	358	573	898	1,740	3,180
Series	Size									
	IN	2"	2.5"	3"	4"	5"	6"	8"	10"	12"
8800G	**Kv	65	137	191	341	553	904	1,612	2,850	4,495
Series	Size									
	IN	2"	2.5"	3"	4"	5"	6"	8"	10"	12"
	8800G	*Cv	77	129	209	358	573	898	1,740	3,180
Series	Size									
	IN	2"	2.5"	3"	4"	5"	6"	8"	10"	12"
8800G	**Kv	66	110	178	305	489	766	1,484	2,712	4,222

Series 8800							
Size		*Cv	**Kv	Size		*Cv	**Kv
IN	MM			IN	MM		
14	350	5,200	4,435	36	900	50,000	42,650
16	400	7,200	8,018	42	1,100	72,000	61,400
18	450	9,400	10,240	48	1,200	97,000	82,740
20	500	12,000	15,780	54	1,144	130,000	112,400
24	600	18,500	28,150	60	1,500	180,000	155,700
30	800	33,000	42,650				

*Cv = The number of U.S. gallons/minute of 60° F water that will flow through the valve with a 1 PSI pressure drop across the valve.

**Kv = The number of cubic meters per hour of 20° C water that will flow through a valve with a 1 bar pressure drop across the valve.

HEAD LOSS CHART

FLOW OF WATER IN METERS PER HOUR

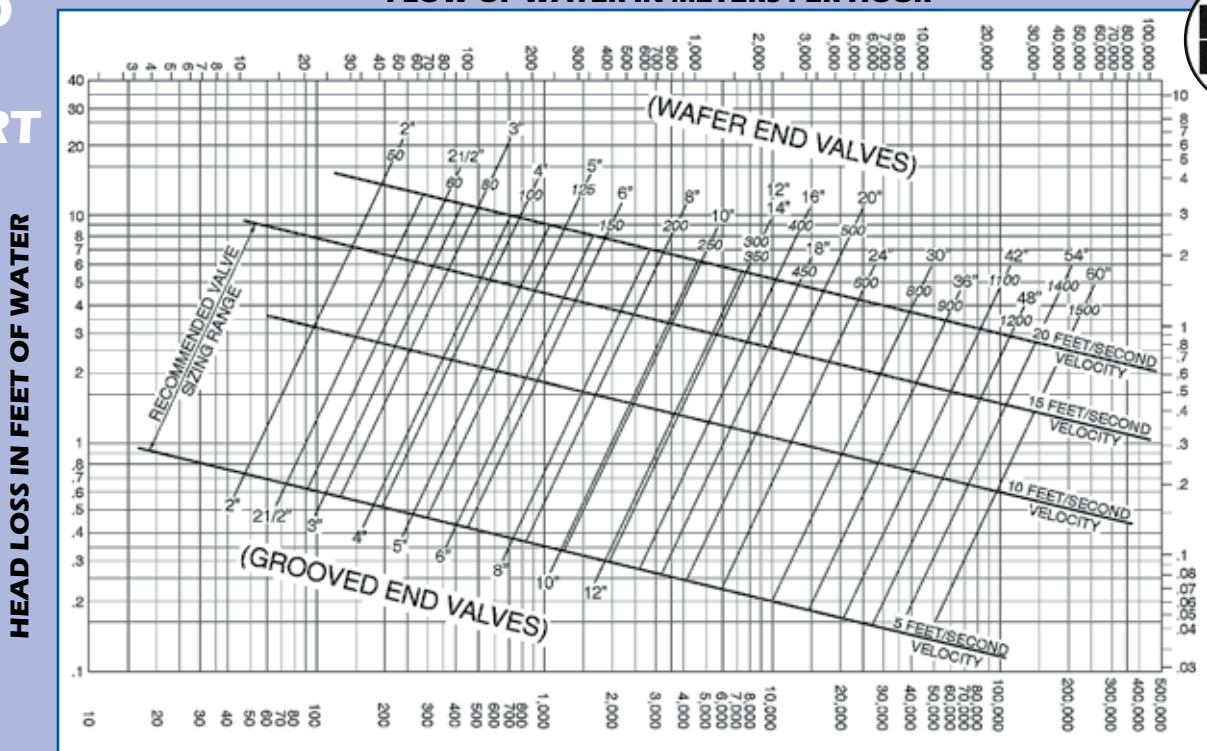

HEAD LOSS IN METERS OF WATER

INSTALLATION DIMENSIONS

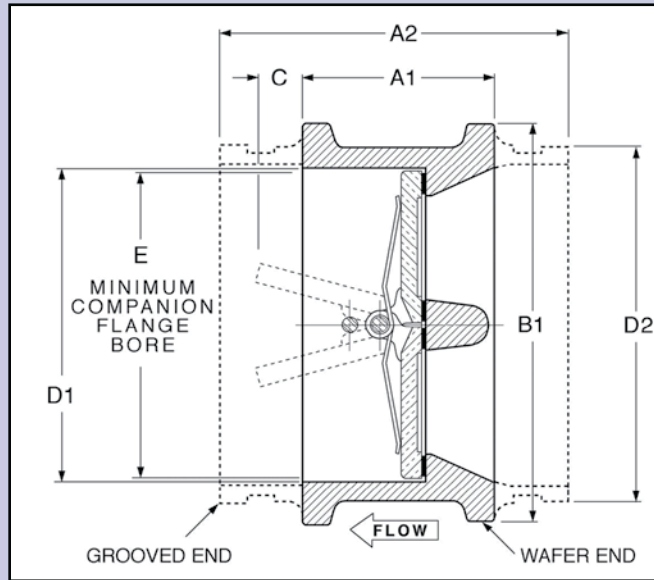
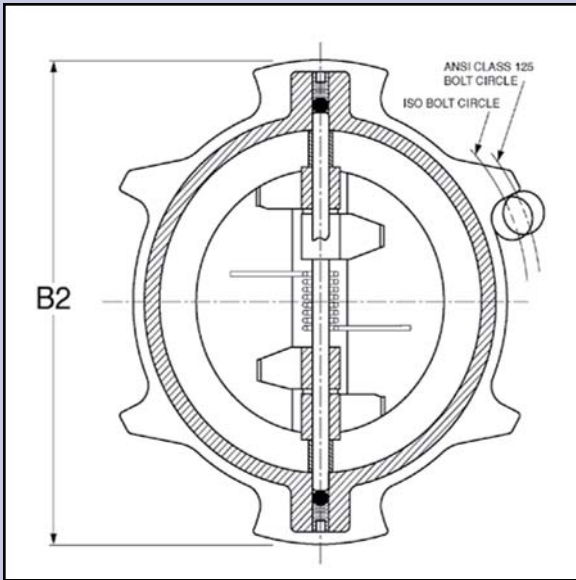

APPROVED

2.5" - 16"
65 - 400mm



2.5" - 12"
65 - 300mm

Valve Size	A1	A2	B1	B2	C	D1	D2	E	Wafer Wt. Lbs. (KG)	Grooved Wt. Lbs. (KG)
2" 50 mm	2.13 54.0	4.66 118.3	4.13 104.8	5.13 130.2	.19 4.8	2.56 65.1	2.38 60.3	1.94 49.2	4 1.8	4 1.8
2.5" 65 mm	2.38 60.3	4.91 124.6	4.88 123.8	5 142.9	.31 7.9	3.06 77.8	2.88 73.0	2.31 58.7	5 2.3	5 2.3
3" 80 mm	2.63 66.7	5.31 134.9	5.38 136.5	6 136.5	.5 12.7	3.69 93.7	3.5 88.9	2.88 73.0	7 3.2	8 3.6
4" 100 mm	2.63 66.7	5.38 136.5	6.88 174.6	7.75 196.9	1 25.4	4.63 117.5	4.5 114.3	3.88 98.4	9 4.1	9 4.1
5" 125 mm	3.25 82.6	5.72 145.3	7.75 196.9	7.56 192.1	1.13 28.6	5.69 144.5	5.56 141.3	4.81 122.2	13 5.9	13 5.9
6" 150 mm	3.75 95.3	6 152.4	8.75 222.3	8.63 219.1	1.25 31.8	6.75 171.5	6.63 168.3	5.75 146.1	19 8.6	18 8.2
8" 200 mm	5 127.0	6.72 170.7	11 279.4	12.25 311.2	1.31 33.3	8.75 222.3	8.63 219.1	7.63 193.7	38 17.2	30 13.6
10" 250 mm	5.5 139.7	7.78 197.6	13.38 339.7	13.75 349.3	2.5 63.5	10.88 276.2	10.75 273.1	9.56 242.9	65 29.5	56 25.4
12" 300 mm	7.13 181.0	8.19 208.0	16.13 409.6	17.38 441.3	2.38 60.3	12.88 327.0	12.75 323.9	11.38 288.9	94 42.6	81 36.7
14" 350 mm	7.25 184.2	N/A	17.75 450.9	N/A	3.25 82.6	14.38 365.1	N/A	12.5 317.5	187 84.8	N/A
16" 400 mm	7.5 190.5	N/A	20.25 514.4	N/A	4.5 114.3	16.38 415.9	N/A	15 381.0	270 122	N/A
18" 450 mm	8 203.2	N/A	21.63 549.3	N/A	5.38 136.5	18.38 466.7	N/A	17 431.8	330 150	N/A
20" 500 mm	8.38 212.7	N/A	23.88 606.4	N/A	6.38 161.9	20.25 514.4	N/A	19 482.6	424 192	N/A
24" 600 mm	8.75 222.3	N/A	28.25 717.6	N/A	8.5 215.9	24.25 616.0	N/A	23 584.2	589 267	N/A
30" 800 mm	12 304.8	N/A	34.75 882.7	N/A	9.5 241.3	30 762.0	N/A	28.5 723.9	1,112 504	N/A
36" 900 mm	14.5 368.3	N/A	41.25 1,048	N/A	12 304.8	36 914.4	N/A	34.5 876.3	1,864 846	N/A
42" 1,050 mm	17 431.8	N/A	48 1,219	N/A	13.75 349.3	42 1,067	N/A	40.5 1,029	2,889 1,310	N/A
48" 1,200 mm	20.63 523.9	N/A	N/A	59.5 1,511	17 431.8	48 1,219	N/A	46.5 1,181	5,525 2,506	N/A
54" 1,350 mm	21.25 539.8	N/A	N/A	66.25 1,683	20 508.0	54 1,372	N/A	52.5 1,334	7,000 3,175	N/A
60" 1,500 mm	26 660.4	N/A	N/A	73 1,854	19 482.6	60 1,524	N/A	58.5 1,486	10,100 4,580	N/A

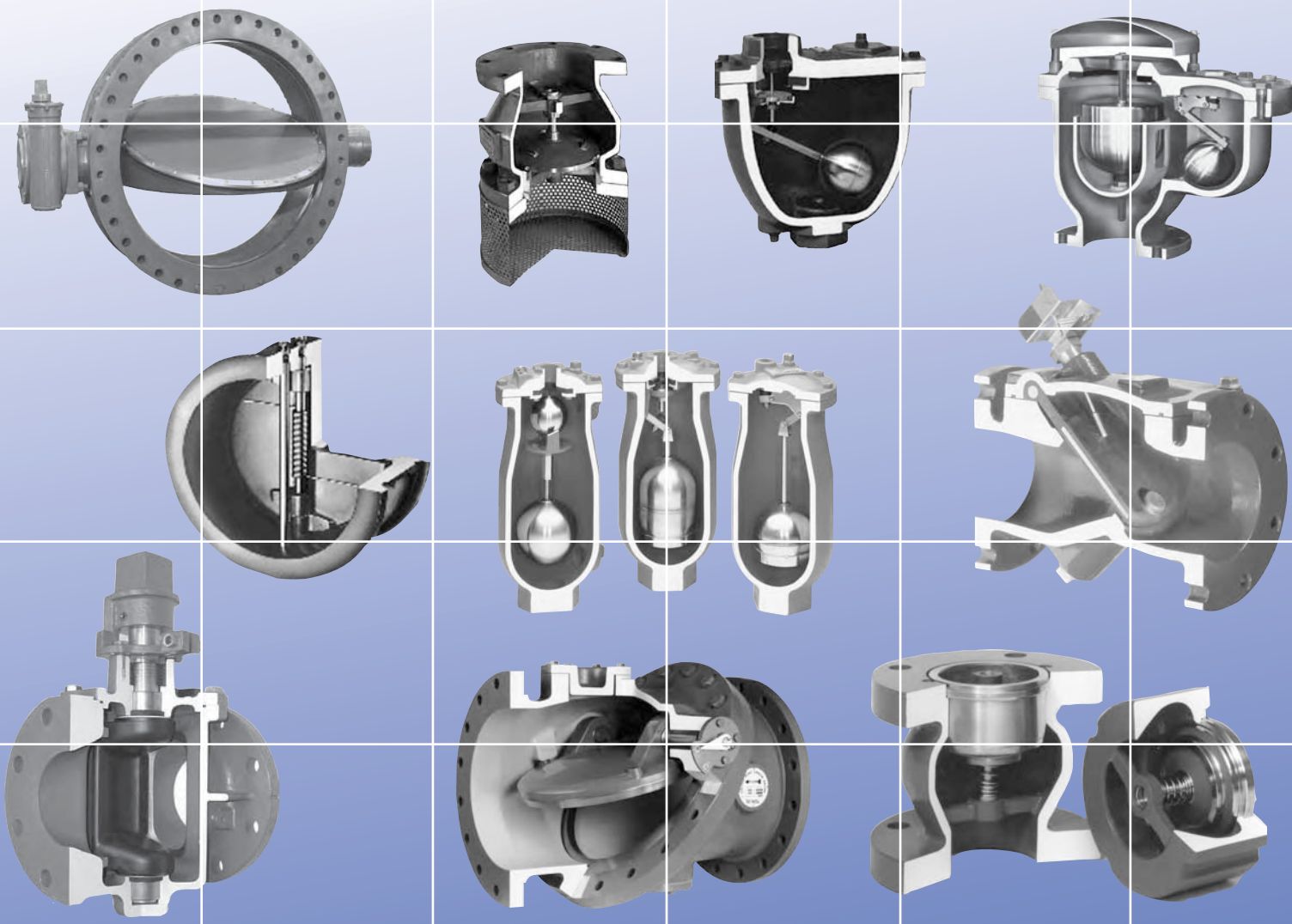

Make the change to **QUALITY!** Specify **VAL-MATIC®**

Val-Matic's quality of design and meticulous workmanship has set the standards by which all others are measured. Quality design features such as Type 316 stainless steel trim as standard on Air Release, Air/Vacuum and Combination Air Valves...combined resilient/metal to metal seating for Silent Check® Valves...stabilized components that provide extended life of the Dual Disc® Check Valves...high strength and wear resistant aluminum bronze trim as standard for Tilted Disc® Check valves...unrestricted full flow area through Swing-Flex® Check Valves...heavy duty stainless steel screened inlet on Sure Seal® Foot Valves...a Cam-Centric®

Plug Valve with more requested features than any other eccentric plug valve, and the American-BFV® Butterfly Valve that provides a field replaceable seat without the need for special tools. These features coupled with our attention to detail put Val-Matic valves in a class by themselves.

Val-Matic is totally committed to providing the highest quality valves and outstanding service to our customers. Complete customer satisfaction is our goal.

VAL-MATIC®

VAL-MATIC VALVE AND MANUFACTURING CORP.

905 RIVERSIDE DRIVE • ELMHURST, IL 60126
630/941-7600 • FAX: 630/941-8042

www.valmatic.com

valves@valmatic.com